

Preliminary

CMOS AREA IMAGE SENSOR

TCM5000D

1 / 4 INCH 330 k PIXEL CMOS B / W IMAGE SENSOR

The TCM5000D is a CMOS B / W image sensor that meets with VGA format. It enables all pixel signals to be output in sequence each 1 / 30 s. (progressive scanning)

This element is equipped with 492 vertical and 659 horizontal signal pixels, and the image size meets with 1 / 4 inch optical format.

Use of the CMOS process enables low power-consumption operations with a single power voltage driving. And it is perfect for use as an image input device for surveillance cameras and other industrial use.

FEATURES

- Optical size : 1 / 4 inch optical format
- Total pixel numbers : 692 (H) × 504 (V)
- Signal pixel numbers : 659 (H) × 492 (V)
- Pixel pitch : 5.6 μm (H) × 5.6 μm (V) (square pixel)
- Image size : 3.6 mm (H) × 2.7 mm (V)
- Package : 16-pin DIP, cerdip
- Frame frequency : 30 Hz
- Power voltage : 3.3 V
- Additional functions : Variable electronic shutter (1 / 30 to 1 / 8000 s)
Monitoring operation (each next horizontal line)

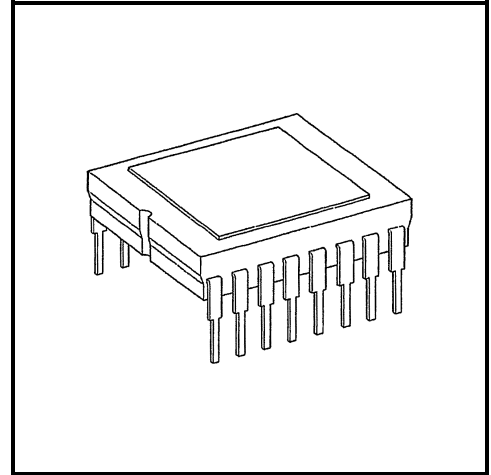

Weight : 1.9g (Typ.)

MAXIMUM RATINGS

CHARACTERISTIC	SYMBOL	RATING	UNIT
Power Supply Voltage	V_{DD}	-0.5~4.2	V
Input Voltage	V_{IN}	-0.5~ $V_{DD} + 0.5$	V
Input Protection Diode Current	I_{IN}	± 20	mA
Storage Temperature	T_{stg}	-30~85	$^{\circ}\text{C}$

RECOMMENDED OPERATING CONDITIONS

CHARACTERISTIC	SYMBOL	RATING	UNIT
Power Supply Voltage	V_{AVDD} V_{DVDD}	3.0~3.6	V
Input Voltage	V_{IN}	0~ V_{DVDD}	V
Operating Temperature	T_{opr}	-20~60	$^{\circ}\text{C}$

PIN CONNECTION

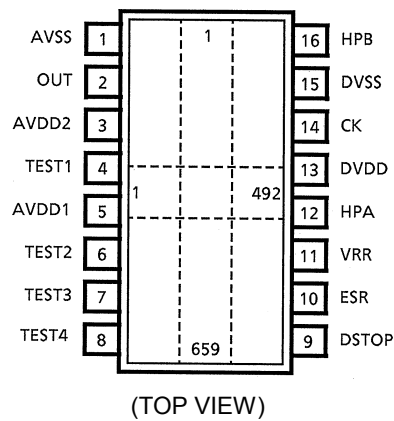

CIRCUIT DIAGRAM

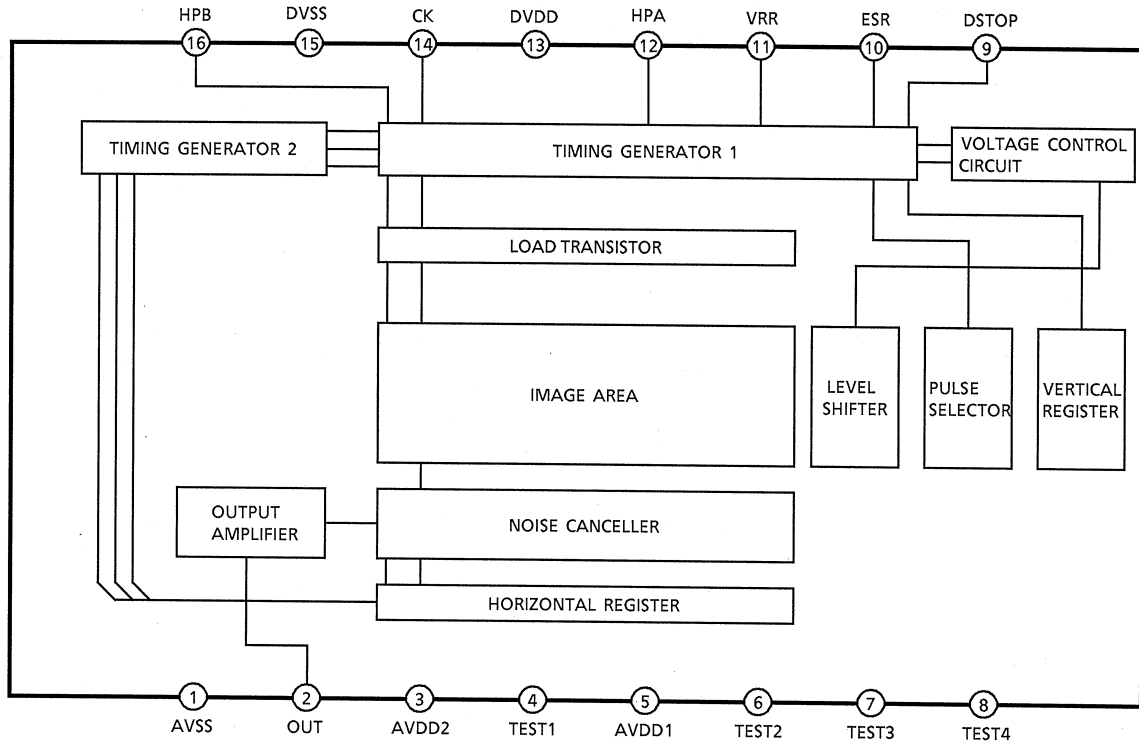

PIN FUNCTIONS

PIN No.	SYMBOL	I / O	FUNCTION
1	AVSS	—	Analog GND
2	OUT	O	Signal output
3	AVDD2	—	Analog power supply 2
4	TEST1	I	Test pin. Normally connected to GND through a capacitor (4.7~10 μ F)
5	AVDD1	—	Analog power supply 1
6	TEST2	I	Test pin 2. Normally connected to GND through a capacitor (4.7~10 μ F)
7	TEST3	I	Test pin 3. Normally connected to GND through a capacitor (4.7~10 μ F)
8	TEST4	—	Test pin 4. Normally H level inputs.
9	DSTOP	I	Operations suspension control pin. H : Normal operations, L : Operations suspended
10	ESR	I	Electrical shutter start pulse input
11	VRR	I	Vertical timing start pulse input
12	HPA	I	Horizontal timing start pulse input
13	DVDD	—	Digital power supply
14	CK	I	Clock pulse input. Double the frequency of signal output.
15	DVSS	—	Digital GND
16	HPB	I	Reading mode switching pin. L : Normal operation (1 V = 525 H, 30 Hz) HPB pulse : Monitoring operation (each next horizontal line, 1 V = 262.5 H, 60 Hz)

OPTICAL AND ELECTRICAL CHARACTERISTICS

CHARACTERISTIC	SYMBOL	TEST CONDITION	MIN.	TYP.	MAX.	UNIT
Sensitivity	R	Standard conditions (* 1)	250	300	—	mV
Saturation Voltage	V _{SAT}		500	600	—	mV
Dark Signal Voltage	V _{DRK}	Ta = 60°C, Dark condition	—	1.0	2.0	mV
Blooming Margin	BLM	Standard light condition	500	—	—	times
S / N (dark)	S / N	Dark condition	55	57	—	dB
Smearing	SMR	1 / 10 V	—	—	-140	dB
Lag	LAG	G output signal : 20 mV, 1 st field	—	0	1	mV
Power Supply Current	I _{DD}	V _{DD} = 3.3 V	—	15	20	mA

* 1: Standard conditions

- Light conditions : Color temperature 3200 K halogen light box. Surface brightness: 100 nt of equal white light.
- IR cut filter
- Optical lens : f25 mm, F0.85 lens manufactured by Fujinon Lens Co., Ltd. Set to the F2.8.
- Frame-frequency : 30 Hz continual operations, electronic shutter off (storage time = 1 / 30 s).

PIXEL ARRANGEMENT

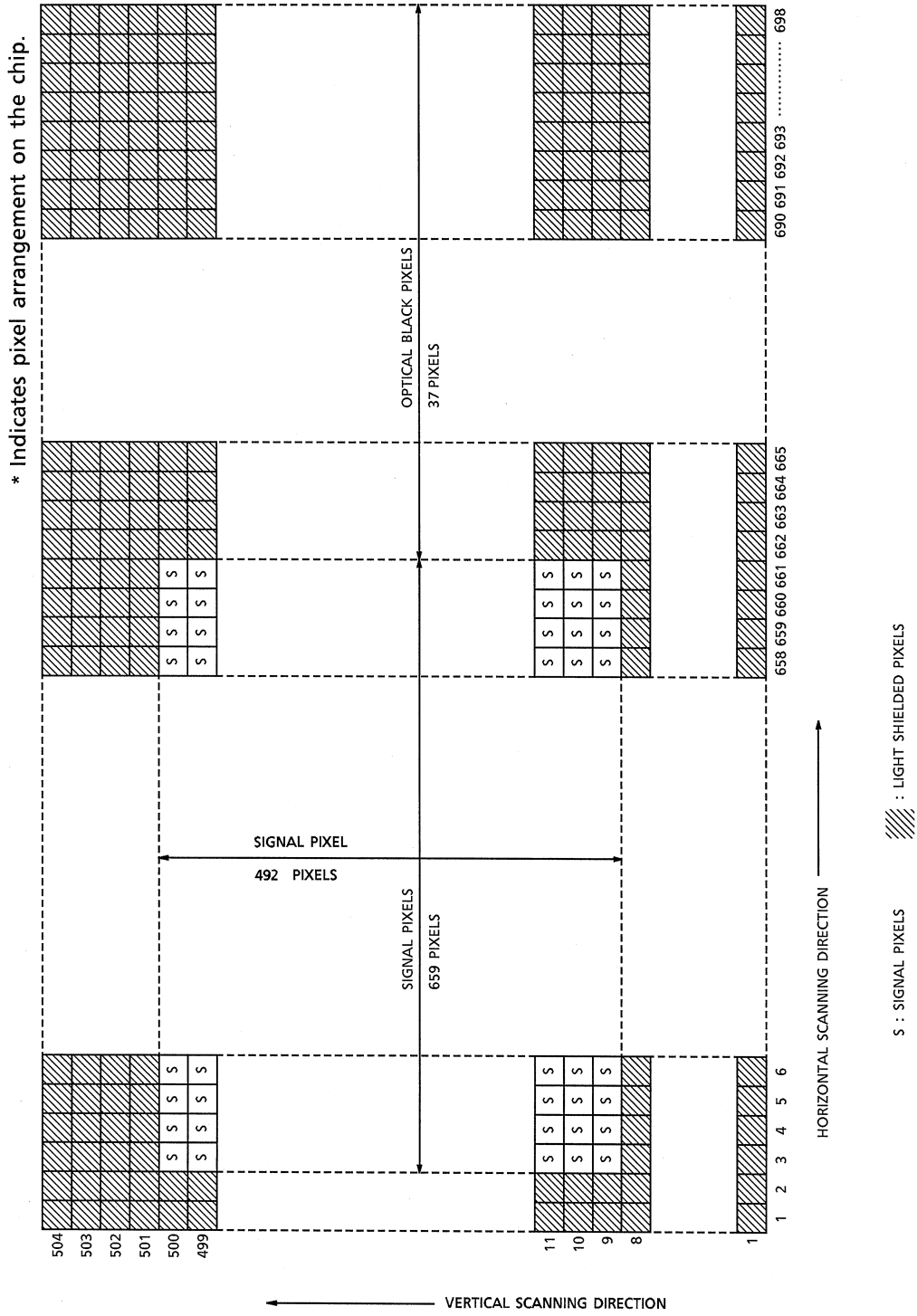

DRIVE TIMING DIAGRAM VGA progressive scanning mode (30Hz, 1V = 525H)

(1) V Blanking

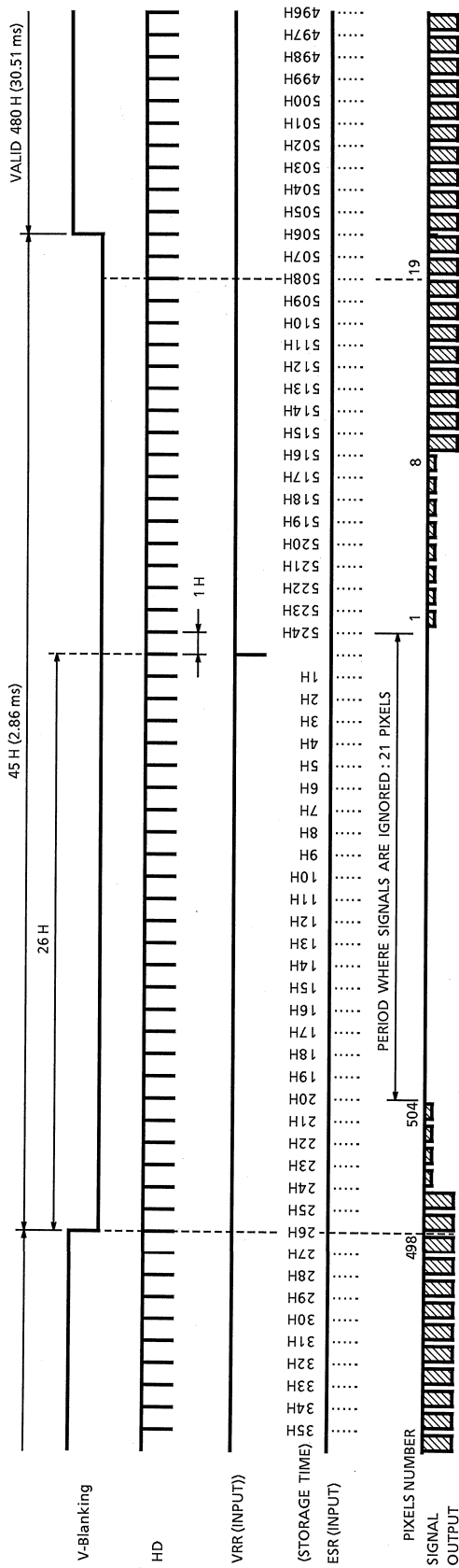

(2) H Blanking

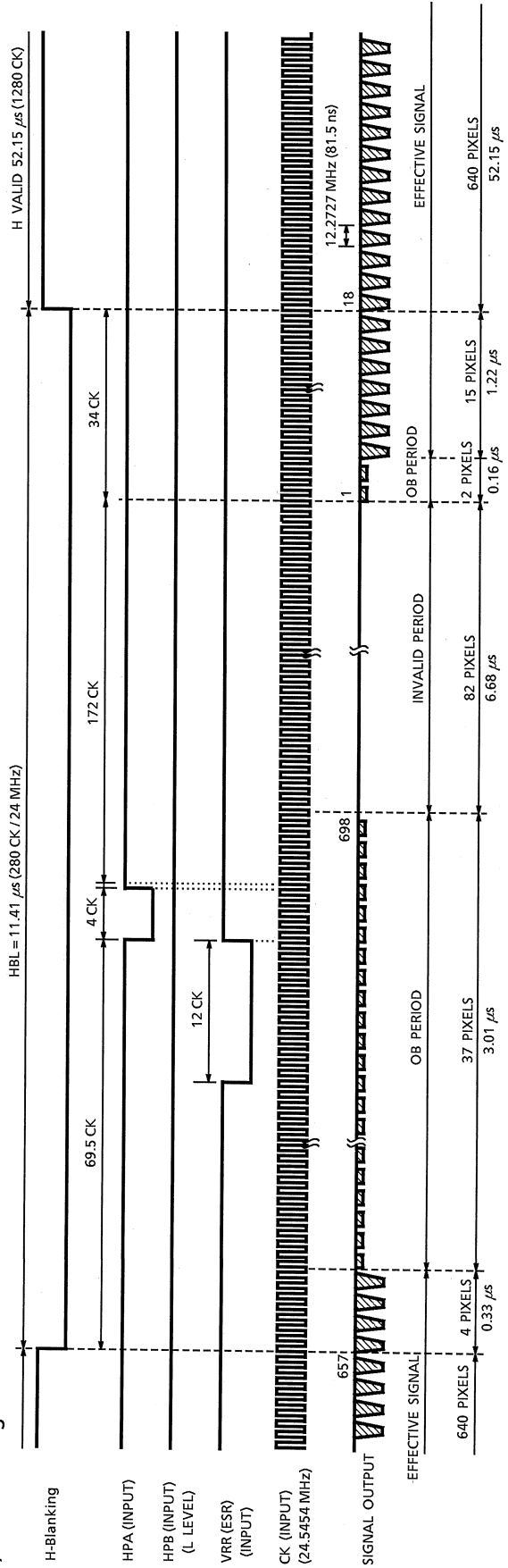

DRIVE TIMING DIAGRAM Monitoring mode

(1) V Blanking

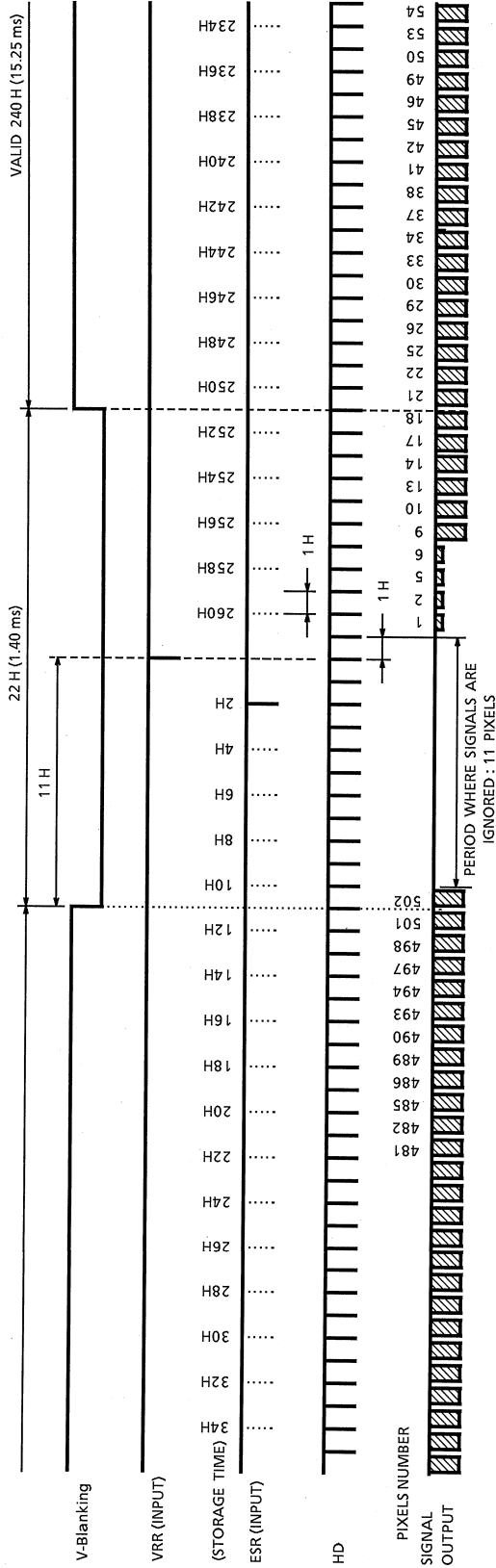

(2) H Blanking

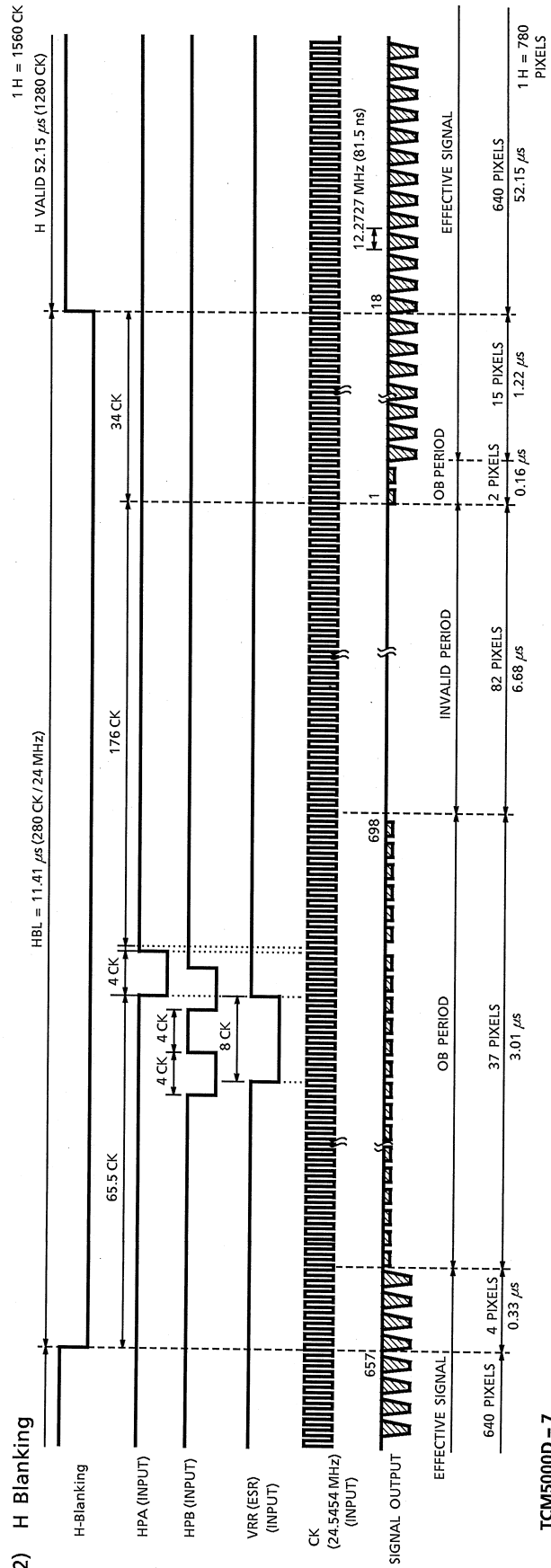

TCM5000D - 7

DRIVE TIMING DIAGRAM

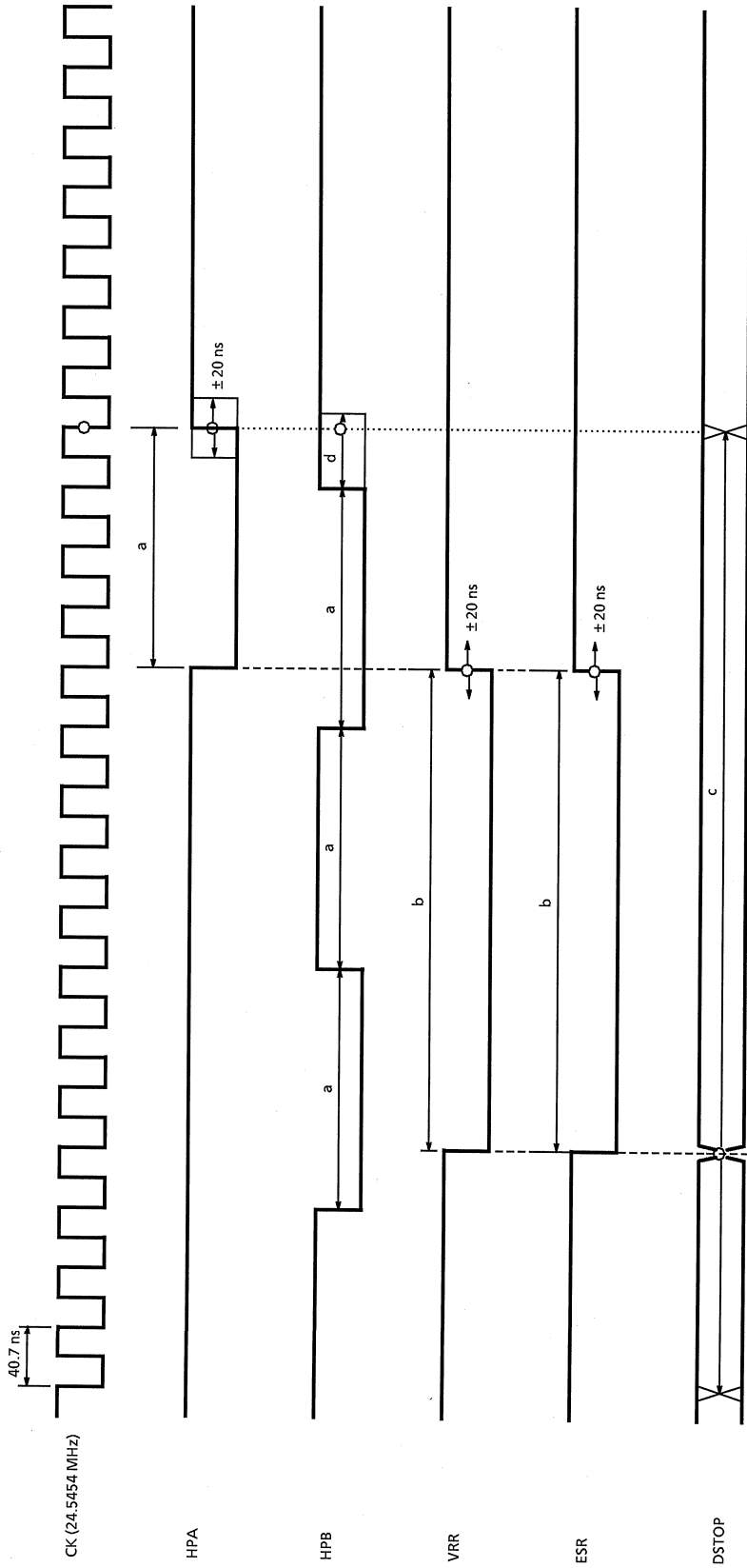

Timing Margin (ns)

	Min.	Typ.	Max.
a	40	163	
b	81	326	
c	-160	0	a + b
d	-81	40	2

(Note 1) : ○ is basic point.

(Note 2) : DSTOP should be changed after VRR (ESR).

(Note 3) : When electronic shutter is not used, H level should be put into ESR terminal once after VDD and CK input.

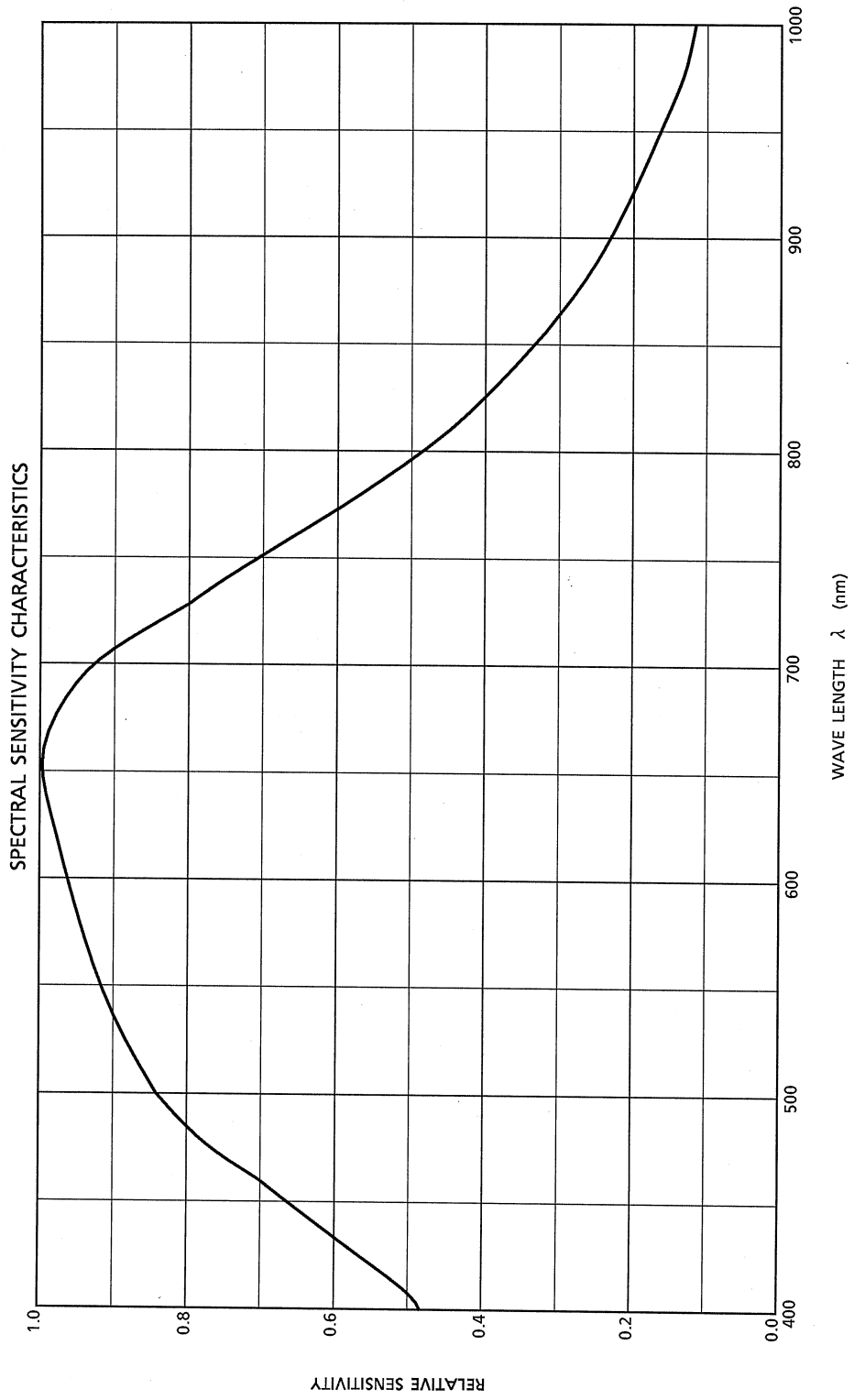

PACKAGE DIMENSIONS

Unit : mm

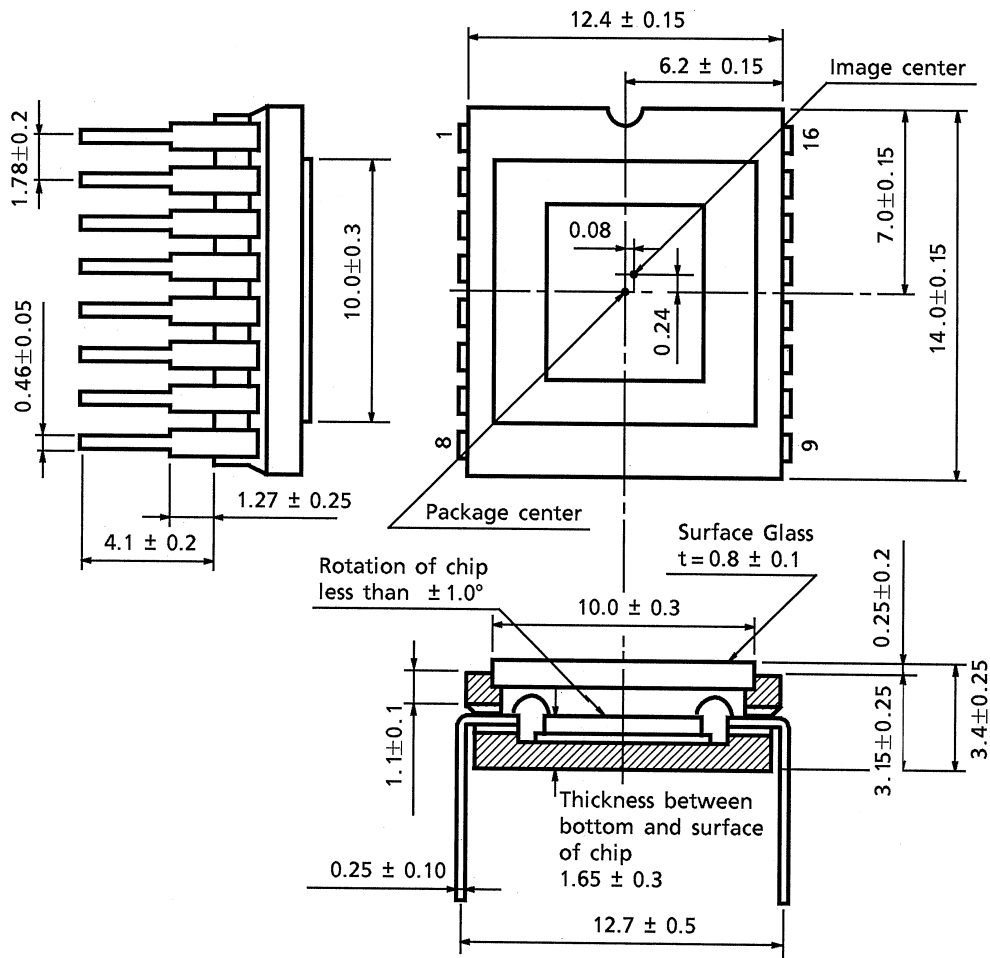

Weight : 1.9 g (Typ.)

RESTRICTIONS ON PRODUCT USE

000707EBA

- TOSHIBA is continually working to improve the quality and reliability of its products. Nevertheless, semiconductor devices in general can malfunction or fail due to their inherent electrical sensitivity and vulnerability to physical stress. It is the responsibility of the buyer, when utilizing TOSHIBA products, to comply with the standards of safety in making a safe design for the entire system, and to avoid situations in which a malfunction or failure of such TOSHIBA products could cause loss of human life, bodily injury or damage to property.
In developing your designs, please ensure that TOSHIBA products are used within specified operating ranges as set forth in the most recent TOSHIBA products specifications. Also, please keep in mind the precautions and conditions set forth in the "Handling Guide for Semiconductor Devices," or "TOSHIBA Semiconductor Reliability Handbook" etc..
- The TOSHIBA products listed in this document are intended for usage in general electronics applications (computer, personal equipment, office equipment, measuring equipment, industrial robotics, domestic appliances, etc.). These TOSHIBA products are neither intended nor warranted for usage in equipment that requires extraordinarily high quality and/or reliability or a malfunction or failure of which may cause loss of human life or bodily injury ("Unintended Usage"). Unintended Usage include atomic energy control instruments, airplane or spaceship instruments, transportation instruments, traffic signal instruments, combustion control instruments, medical instruments, all types of safety devices, etc.. Unintended Usage of TOSHIBA products listed in this document shall be made at the customer's own risk.
- The products described in this document are subject to the foreign exchange and foreign trade laws.
- The information contained herein is presented only as a guide for the applications of our products. No responsibility is assumed by TOSHIBA CORPORATION for any infringements of intellectual property or other rights of the third parties which may result from its use. No license is granted by implication or otherwise under any intellectual property or other rights of TOSHIBA CORPORATION or others.
- The information contained herein is subject to change without notice.